



REV	C	<b>APPLICATION</b>			<b>REVISIONS</b>		
		PRODUCT LINE	REV	DESCRIPTION	DATE	APPROVED	APPROVED
SH	1	IDU-III	A	Initial Release per DCN W4346	4-7-05	R. Durall	DAC
			B	Change per DCN W4430	04/15/05	R. Durall	R. DeLong
DWG. NO.	150-045151		C	Change per DCN W4931	01/16/06	R. Durall	V. Wallace

THIS DOCUMENT CONTAINS PROPRIETARY INFORMATION OF WULFSBERG ELECTRONICS, A CHELTON GROUP COMPANY, NEITHER RECEIPT NOR POSSESSION THEREOF CONFERS ANY RIGHT TO REPRODUCE OR USE, OR DISCLOSE, IN WHOLE OR IN PART, ANY SUCH INFORMATION WITHOUT WRITTEN AUTHORIZATION FROM WULFSBERG ELECTRONICS

		 <b>Wulfsberg Electronics</b> <i>A Chelton Group Company</i>	
<b>APPROVALS</b>			
DRAWN	R. Durall	4-4-05	<b>TITLE:</b> <b>SERVICE BULLETIN WSB IDU-III-15</b> <b>(SOFTWARE APPLICATION VERSION 5.0B)</b>
CHECKED	D. Boston	4-4-05	
PRODUCT MANAGER	---	---	
ENGINEER	R. Durall	4-4-05	<b>SIZE</b> 
ISSUED	R. Talken	4-7-05	<b>CAGE CODE</b> <b>1B7G3</b>
		<b>DWG NO.</b> <b>150-045151</b>	<b>REV</b> <b>C</b>
<b>Typed signatures indicate approval. Handwritten signature approval of this document is on file at Wulfsberg Electronics, Prescott, Arizona.</b>		<b>SCALE: NONE</b>	<b>DO NOT SCALE DRAWING</b>



**Wulfsberg Electronics**  
A Chelton Group Company

## SERVICE BULLETIN

**EQUIPMENT:** IDU-III

**DATE:** January 16, 2006

**BULLETIN NUMBER:** WSB IDU-III-15 Revision C

### MANDATORY SERVICE BULLETIN

#### EFFECTIVITY

This service bulletin is mandatory for the following equipment under STCs SA02203AK, SA02220AK, SA02232AK, SR02209AK and SR02230AK:

LRU P/N	HDWR Mod	SWID
401-045500-[ ]	0101	5.0A or Lower

#### REASON

##### Features and Changes:

1. Enhanced presentation of altitude leg waypoints by fixing position when within the level-off range from the altitude termination;
2. Apply roll rate limiting, look-ahead function and “all-angle” intercept function into autopilot roll-steering output to improve autopilot control;
3. Eliminate auto-declutter of  $V_{enr}$  setting;
4. Eliminate GROUND MODE bank = 0° patch due to improved algorithms in Crossbow AHRS;
5. Enable smooth course datum transition at 180° point to support localizer back course modes of certain autopilots;
6. Automatically inhibit EGPWS Mode 5 (Glideslope) below 200’AGL to get rid of spurious warnings caused by side lobes of glideslope beam on missed approach;
7. Extensive revision of VNAV system as follows:
  - a. Target altitude controls altitude pre-select function (immediate climbs and descents).
  - b. VNAV altitudes for flight plan waypoints are individually settable. Flight plan waypoints without manually or navdata-set altitudes are auto-filled.

- c. VNAV altitudes are settable in increments of 100' (most waypoints) or 10' (IAP waypoints).
  - d. VNAV altitudes shown in waypoint listing. Manually or navdata-set altitudes are normal-colored. Auto-filled altitudes are magenta.
  - e. When a target altitude is not set, VNAV altitudes are shown in PFD active waypoint box. Manually or navdata-set altitudes are normal-colored. Auto-filled altitudes are magenta.
  - f. Guidance and HITS track target altitude (altitude pre-select function) or, if no target altitude, VNAV altitude.
  - g. Climb/Descent arc is dynamic.
  - h. Eliminate "Descend Now" function.
  - i. Add separate climb speed bug so that speed deviation alerts do not occur on level-off.
  - j. VNAV bug is magenta. VNAV altitude annunciation is magenta. Target altitude bug and target altitude annunciation take priority over VNAV.
  - k. PFD bug menu uses soft keys instead of scroll box.
  - l. Minimum altitude bug always set in 10' increments.
  - m. Target altitude bug always set in 100' increments.
  - n. INFO box always shows elevation.
  - o. VNAV climb and descent angles cannot be set to 0.
8. Retain ND/PFD declutter settings between power cycles;
  9. Move airway and airspace declutter functions from ND symbol declutter menu to ND function declutter menu;
  10. Add borders to ND and flight planner;
  11. Enable declutter of ND glide range;
  12. Improve automatic ND symbol declutter algorithm;
  13. Add ETA function to ND;
  14. Improve airway labeling where multiple airways share same leg;
  15. Add ISA temperature display to ND;
  16. Add distance test for transitioning to VFR Approach mode;
  17. Add traffic thumbnail to PFD and inhibit traffic popups on ND when in approach mode or when glideslope signal is active;
  18. Fix timer start bug related to continuous transmission of settings between EFIS screens;
  19. Fix remote tuning bug related to continuous transmission of settings between EFIS screens;

20. Fix Direct-To bug for DP waypoints;
21. Fix parallel offset function bug;
22. Correct display of destination information on ND where waypoints exist past an approach procedure; and
23. Correct software reversal of UPS and warning light outputs.

**NOTE:** *An undetected failure of an external Marker Beacon receiver may cause the EFIS to continually display the furthest Marker from the airport. Consult the appropriate Chelton Flight Manual Supplement, Section 3.2.F for additional details.*

### **DESCRIPTION**

This modification updates the application software to 5.0B.

### **COMPLIANCE**

Required for all installations listed under the Effectivity section of this Service Bulletin.

### **WARRANTY INFORMATION**

Units still in the warranty period may request this modification under the terms of the warranty agreement. Inquiries should be directed to "Customer Support" at the address listed below:

Chelton Flight Systems  
1109 Main Street, Suite 560  
Boise, ID 83702  
Phone: (208) 389-9959  
Fax: (208) 389-9961

Warranty claims will not be reimbursed unless a copy of the completed log book entry including all IDU Serial Numbers is supplied with the warranty claim.

### **APPROVAL**

This Service Bulletin has been reviewed and approved by the FAA.

This modification does not affect the original approval.

### **MANPOWER**

1.0 Man-hours per aircraft.

## **REFERENCES**

System Installation Instructions, 150-045264.

## **MATERIAL INFORMATION**

The parts required to modify an IDU-III in accordance with this Service Bulletin may be obtained by contacting Chelton Flight Systems Sales Department at (208) 389-9959.

Items 1, 2, 3, 4, 5, 6, and 7 are contained in the 5.0B Service Bulletin Kit, P/N SW050BKIT. Items 2 and 3 are programmed on Item 1.

Item 4 may also be downloaded from the Chelton Flight Systems web site at [www.cheltonfs.com](http://www.cheltonfs.com) by selecting "DEALERS" menu item and logging into the Dealers web site.

Items 5 and 6 may also be downloaded from the Chelton Flight Systems web site at [www.cheltonfs.com](http://www.cheltonfs.com) by selecting "DEALERS" menu item and logging into the Dealers web site for the appropriate STC.

## **PARTS REQUIRED**

<b><u>ITEM</u></b>	<b><u>QTY</u></b>	<b><u>U/M</u></b>	<b><u>PART NUMBER</u></b>	<b><u>DESCRIPTION</u></b>
1	1	Ea	N/A	SmartMedia card, 16MB
2	1	Ea	320-145239-050B	Software Load Module, Update Image 5.0B
3	1	Ea	320-145954-0210	Software Load Module, Upgrade Image 5.0B
4	1	Ea	150-045240 Rev G	Pilot's Operating Handbook Insert, EFIS SW Ver 5.0B
5	1	Ea	Various	Instructions for Continued Airworthiness
6	1	Ea	Various	Flight Manual Supplement
7	4	Ea	156-045976-01	Label, DO-178B Level A

### **CAUTION**

ANY DISASSEMBLY/ASSEMBLY OF THIS UNIT MUST BE DONE AT A STATIC SAFE WORKSTATION. REMOVED MODULES SHOULD BE PLACED IN ANTISTATIC BAGS WHEN NOT INSTALLED IN THE UNIT.

## **IDU MODIFICATION PROCEDURE**

***NOTE:*** Steps 1 through 15 listed below describe the update process for one IDU. These steps must be performed for all IDU(s) in the aircraft.

## **APPLICATION SOFTWARE UPDATE (PFD AND MFD)**

1. Apply external power to the aircraft.
2. Ensure power is removed from the IDU(s).
3. Insert the SmartMedia card (Item 1) from the Service Bulletin Kit into the PFD or single IDU.
4. Apply power to the IDU(s).

5. Verify the PFD or single IDU displays the Ground Maintenance menu (see Figure 1).

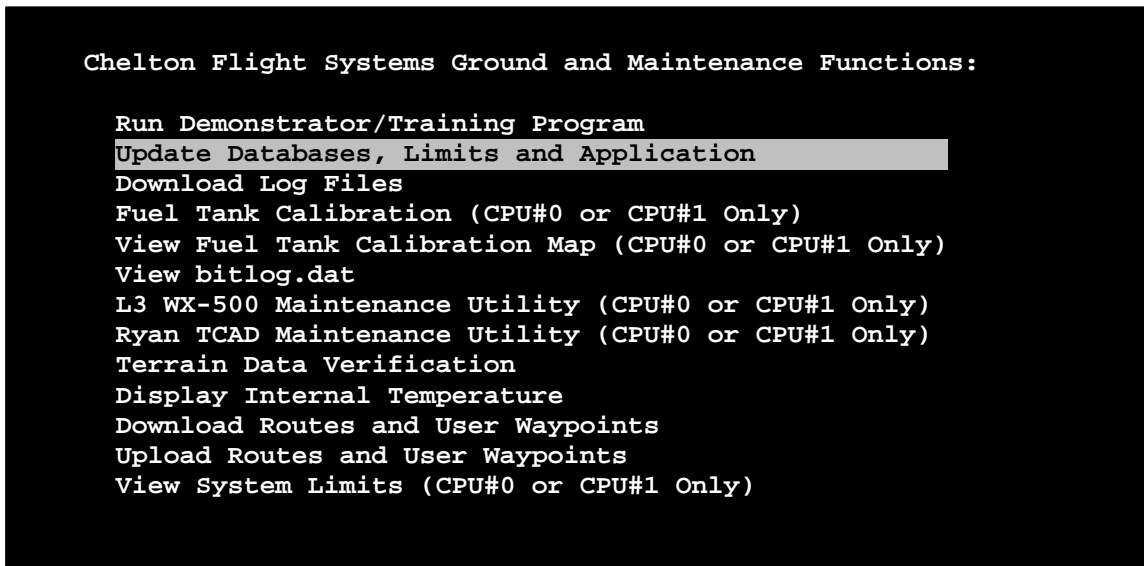

**Figure 1 Ground Maintenance Menu**

6. Rotate the right-hand encoder until the “Update Databases, Limits and Application” is highlighted then press in the right-hand encoder.
7. Verify the “absrun” software has been loaded (See Figure 2 for details). This should take approximately 5 seconds.

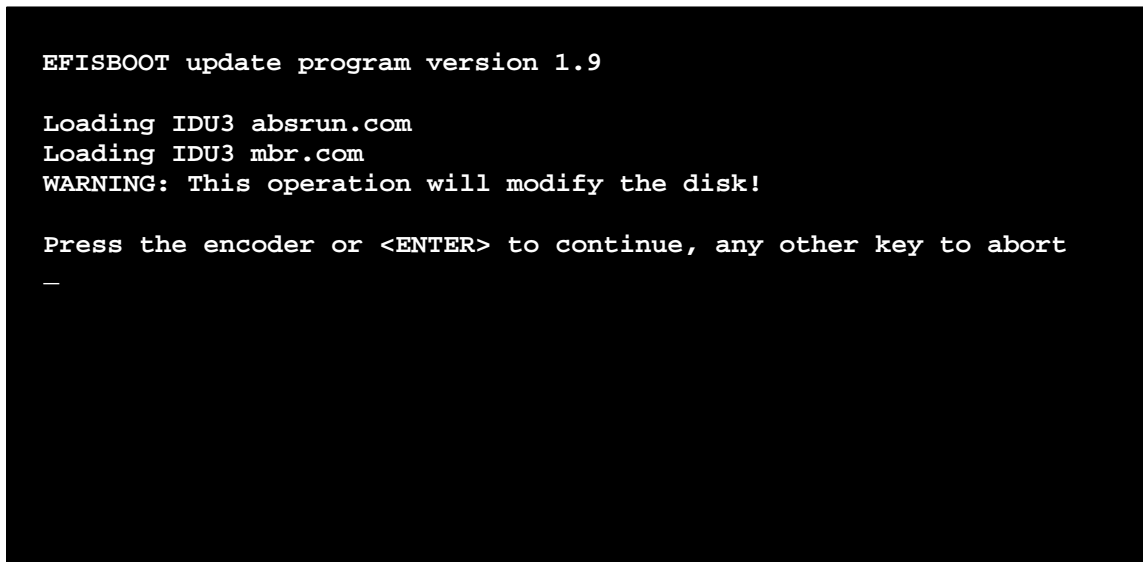

**Figure 2 “Absrun” Software Load**

8. Press the right-hand encoder on the unit or the <ENTER> key on an external keyboard when the “Press the encoder...” is displayed.
9. Verify the “absrun” and “MBR” software have been written to the IDU disk (See Figure 3 for details). Press any button or the right-hand encoder on the unit when the “Press any key to continue...” is displayed.

```
EFISBOOT update program version 1.9

Loading IDU3 absrun.com
Loading IDU3 mbr.com
WARNING: This operation will modify the disk!

Press the encoder or <ENTER> to continue, any other key to abort
COM program (e:\absrun.com) written to disk.
MBR (e:\mbr.com) and MBR data fields written to disk.
Press any key to continue. . .
—
```

**Figure 3 “Absrun” Software Download Complete**

10. Verify the application software has been downloaded (See Figure 4 for details). This should take approximately 15 seconds to download.

```
Inflating: d:/UTIL/257928.GM
Inflating: d:/UTIL/258184.GM
Inflating: d:/UTIL/258440.GM
Inflating: d:/UTIL/BAT_MENU.EXE
Inflating: d:/UTIL/DOS4GW.EXE
Inflating: d:/UTIL/FUELVIEW.EXE
Inflating: d:/UTIL/GMIDX.EXE
Inflating: d:/UTIL/IDU_FCAL.EXE
Inflating: d:/UTIL/LIM_DSPL.EXE
Inflating: d:/UTIL/PUTLIMIT.EXE
Inflating: d:/UTIL/RTE_CHK.EXE
Inflating: d:/UTIL/S100A030.LOG
Inflating: d:/UTIL/SIMULATE.EXE
Inflating: d:/UTIL/TCADTEST.EXE
Inflating: d:/UTIL/TEMP.EXE
Inflating: d:/UTIL/TERR_BIT.EXE
Inflating: d:/UTIL/TPI.TXT
Inflating: d:/UTIL/USNEXRAD.DAT
Inflating: d:/UTIL/WX_TEST.EXE
Inflating: d:/UTIL/XBOW_CAL.EXE
      1 file(s) copied
      1 file(s) copied
      1 file(s) copied
Press any key to continue . . .
```

**Figure 4 Typical IDU display when update is completed**

11. Press any button or right-hand encoder on the unit when the “Press any key to continue . . .” is displayed.
12. Ensure the Ground Maintenance menu is displayed after the unit performs a scan of both internal drives.
13. Repeat steps 6 thru 12 a second time to ensure the update procedure has been completed.
14. Remove power from the IDU(s).
15. Remove the SmartMedia card.
16. Repeat steps 1 thru 15 for all remaining IDU(s) in the aircraft.

**LABEL MODIFICATION**

1. Ensure power is removed from the aircraft.
2. Remove the PFD from the tray by inserting a 3/32” hex-head wrench into the locking hole located in the lower right-hand area of the IDU (see **Figure 5**), and rotate counter-clockwise until the IDU no longer moves out from the Instrument Panel. Grasp the sides of the IDU and pull out from the panel.



Figure 5 IDU Bezel

3. Locate the IDU-III TSO Label and the ID Label on the back of the IDU (see **Figure 6**). Early production IDUs were manufactured with an ID label style shown in **Figure 7**.

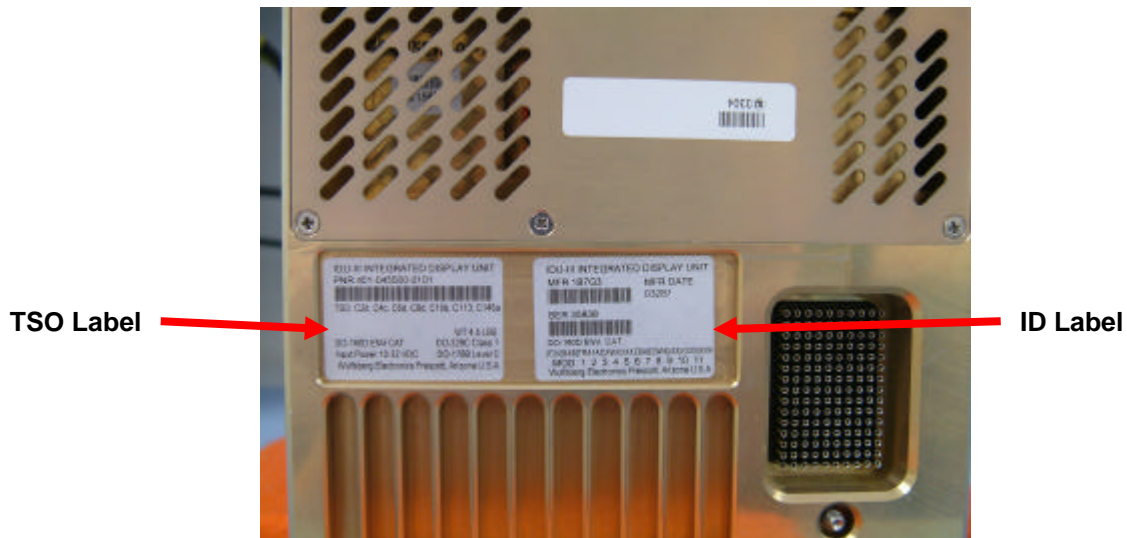

Figure 6 IDU Rear View

**NOTE:** ID Label and TSO Label may be in opposite locations depending on manufacturer's application.

4. If either label contains the statement "DO-178B Level C", remove the statement using a black felt pen with permanent ink (see **Figure 7** and **Figure 8**).



**Figure 7 Original ID Label**



**Black-out Statement**

**Figure 8 TSO Label**

5. Remove the paper backing from the new DO-178B Label (Item 7) and apply on the IDU above the J1 connector as shown in **Figure 10**. Ensure the new label does not interfere with the J1 connector, and is mounted on the rear bulkhead assembly, not the fan cover located on the top section of the rear bulkhead assembly.

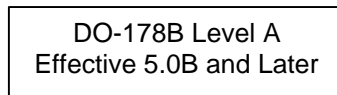

**Figure 9 DO-178B Level A Label (Item 7)**



**Figure 10 Typical DO-178B Level A Label Location**

6. Document the Serial Number of the IDU on the Log Book Entry form included with the Service Bulletin Kit.
7. Insert the IDU into the tray and gently press the bezel until the IDU stops.
8. Insert the 3/32" hex-head wrench into the locking hole and slowly rotate clockwise while pressing on the bezel until the unit is fully seated and the wrench will not turn.
9. Repeat Steps 1 thru 8 for each additional IDU in the aircraft.

## **TESTING PROCEDURES**

**NOTE:** Before proceeding with this section, ensure all IDU(s) in the aircraft have been updated per the Application Software Update (PFD and MFD) section and the Label Modification section of this Service Bulletin.

1. Apply power to the EFIS system and verify each IDU completes initialization and testing.
2. Verify the information listed below is displayed on each modified IDU status page (See **Figure 11**):
  - a. "Rev 5.0B-10"
  - b. "SOFTWARE OK"

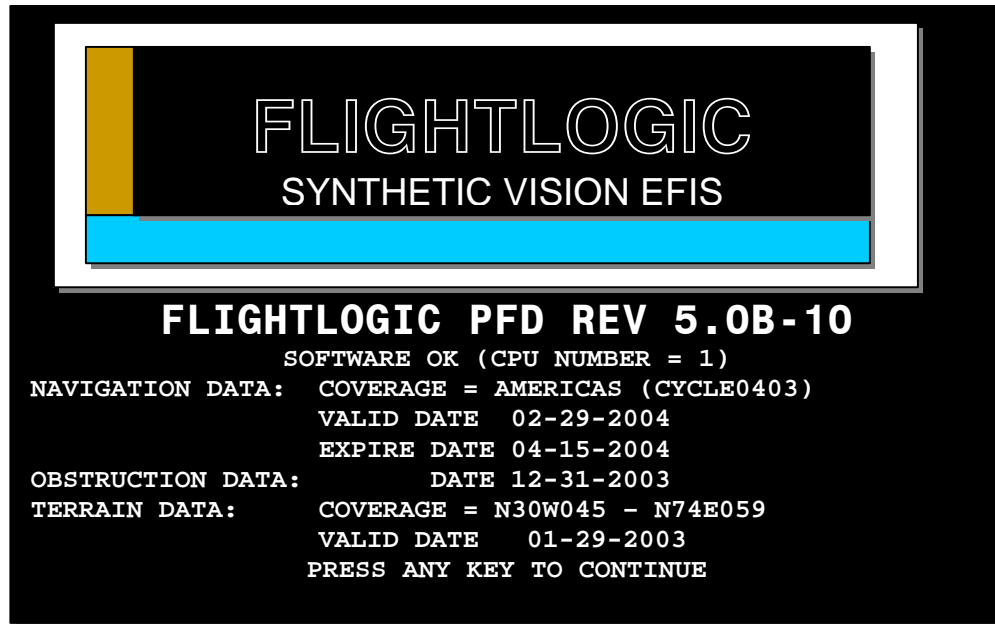

**Figure 11 Typical EFIS Status Page**

**NOTE:** PFD/MFD and CPU Number will depend on the position of the IDU.

3. Press any button or the right-hand encoder on each IDU and verify the EFIS system starts normal operation.

**NOTE:** If any IDU does not complete initialization and/or self-test, it may be necessary to repeat the modification process to reload the EFIS software. If the IDU does not operate properly after two load processes, contact Chelton Flight Systems Technical Support at (208) 389-9959.

### **SFIM AUTOPILOT ALTERATION**

Rotorcraft with the EFIS interfaced to a Sfim PA-85 autopilot under Chelton STC SR02209AK or SR02230AK must modify the wiring as follows using Figures 12 and 13 below:

1. Locate and install a DPDT relay in the aircraft. The relay shall be mounted using material, hardware, and techniques as outlined in FAA AC 43.13-1B and 2A or later revision.
2. Disconnect the wire from P2-Pin 17 of the Litef LCR-93 AHRS.
3. Extend this wire and connect to the wiper of the relay installed in Step 1.
4. Install a new wire from the EFIS MFD P2-Pin 18 to the low side of the relay coil.
5. Use or install a circuit breaker on the EFIS bus labeled "EFIS SWITCHING".
6. Install a new wire from the circuit breaker to the high side of the relay coil and the Normally-Closed contact of the relay.
7. Install a new wire from the Normally-Open contact of the relay to airframe ground.

- Using the IDU Limits program, set the EFIS Autopilot Valid Polarity to "Open = EFIS Valid" (See EFIS Installation Manual, Doc. 150-045264 or 150-045057, Chapter 5 for further details on programming the IDU Limits).

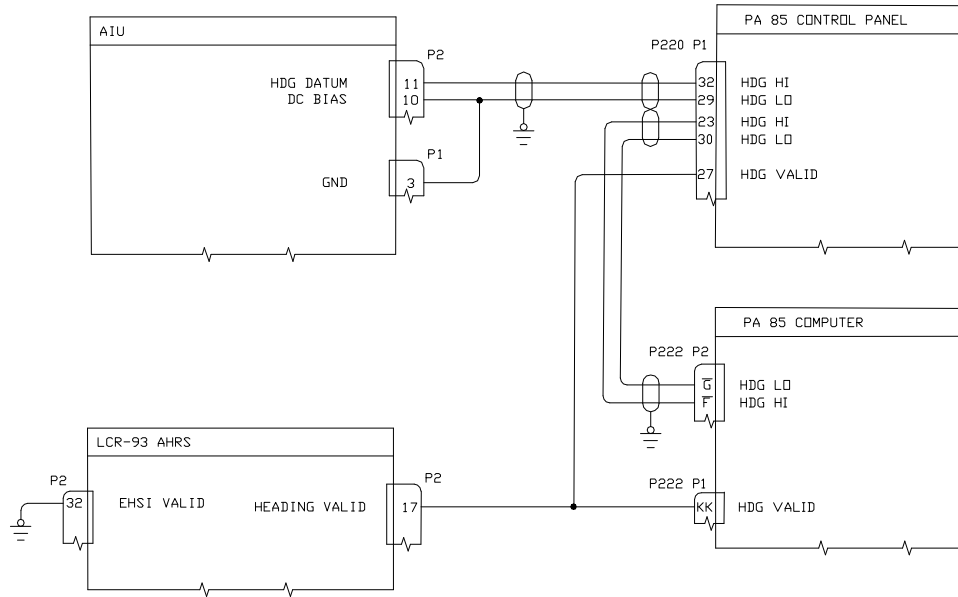

**Figure 12 Old EFIS to Sfim PA-85 Wiring Diagram**

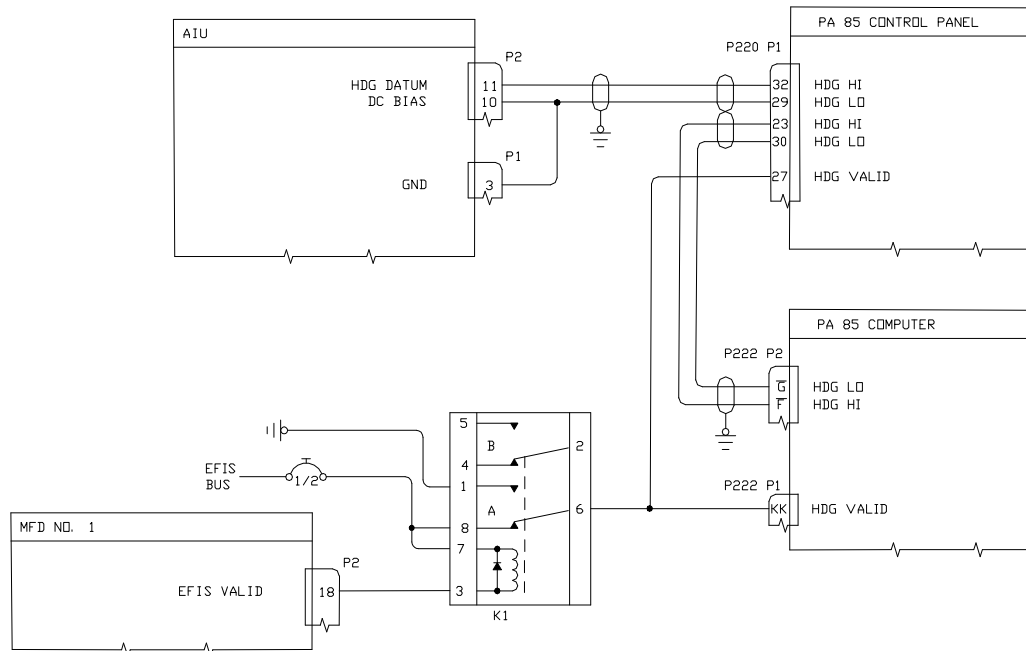

**Figure 13 New EFIS to Sfim PA-85 Wiring Diagram**

## **DOCUMENT UPDATE**

1. Remove and replace the Pilot's Operating Handbook insert (Item 4). Destroy the removed version.
2. Remove and replace the Instructions for Continued Airworthiness (Item 5). Destroy the removed version.
3. Remove and replace the Flight Manual Supplement (Item 6). Destroy the removed version.
4. Obtain a copy of the completed aircraft log book entry and return to Chelton Flight Systems.